

QUANTUM RADIOMETER
MODELS Q203 & Q203 PAR
HANDBOOK

Contents:	1 Introduction
	2 Specification
	3 Operation
	4 PAR Measurements
	5 Irradiance Measurements
	6 Illuminance Measurements
	7 Cosine Angular Response
	8 Calibration Description
	9 Care and Maintenance
	10 Optional Accessories
	11 Block Diagram
	12 Programming via the RS232 interface

Handbook Ref No.	MH077/Issue F
File Ref:	Q203V5F.WPS

Handbook Update Log

<u>Issue</u>	<u>Date</u>	<u>Pages changed</u>
A	15/7/99	New Issue
B	1/3/00	Update for Version 4 μ P
E	19/2/02	Version 5 update
F	12/3/03	New filter variations & corrections.

1 INTRODUCTION

The Macam portable digital Quantum radiometers models Q203 and Q203 PAR are versatile direct reading instruments designed specifically for measuring photosynthetic active radiation (PAR 400 and 700nm) in units of $\mu\text{mol}\cdot\text{m}^{-2}\cdot\text{s}^{-1}$ (micro Einstein. $\text{m}^{-2}\cdot\text{s}^{-1}$).

The model Q203 can also be configured to measure irradiance between 400 and 1000nm (or 700nm) in $\text{W}\cdot\text{m}^{-2}$ and illuminance in LUX.

These alternative measurement units are obtained through interchangeable cosine corrected filter rings which adapt the detector response to correspond to the desired spectral sensitivity profile.

Both radiometers comprises of a Q203X handheld display unit with Lithium battery, SD222-33 laboratory detector and integral amplifier, with interconnecting cable, and a PAR Cos-112 cosine corrected filter ring. Model Q203 also includes a RFF Cos-112 (or RFF-VIS Cos-112) irradiance filter ring and CIE Cos-112 illuminance filter ring. The meters also include a RS232 interface cable, calibration certificate and CC-4 carrying case.

The Q203 may be used in applications such as Agriculture, Horticulture, Plant Growth studies, Biology, Liminology (with under water detectors), Environmental studies and Illumination engineering.

2 SPECIFICATION:

DISPLAY UNIT	Q203X
Controller:	80C51 8bit micro-processor with a 3.1684MHz clock.
Memory	On board non volatile RAM for calibration factors and set-up parameters.
Key Operation	8 switch key board with 11 LED indicators.
Power Switch	Microprocessor reset at switch on. Unit settings stored prior to shut down.
Serial Interface	Three wire RS232 serial interface. 4800 baud, no parity, 1 stop bit.
Integration Time	0.33s
Conversion Scale	17 bit
Accuracy:	Measurement accuracy ± 1 digit with a linearity error of $<1\%$.
Display:	4½ digit lcd display. Character height 10mm.
Display illumination:	A LED back light can be switched on to illuminate the display for readings in low ambient light situations.
Power Supply:	9 volt 1200mAh, PP3 Lithium Manganese.
Power Consumption:	Shut down mode <5µA Operating 10 - 20mA LED back light ~20mA
Battery Life	~ 50 hours without backlight use

2 SPECIFICATION (continued):

Ranges: i) PAR (*both models*)
 Up to 6 full scale decades measuring from*:
 0 to 1.9999 $\mu\text{mol.m}^{-2}.\text{s}^{-1}$
 0 to 19.999 $\mu\text{mol.m}^{-2}.\text{s}^{-1}$
 0 to 199.99 $\mu\text{mol.m}^{-2}.\text{s}^{-1}$
 0 to 1999.9 $\mu\text{mol.m}^{-2}.\text{s}^{-1}$
 0 to 19999 $\mu\text{mol.m}^{-2}.\text{s}^{-1}$
 0 to 19999 x 10 $\mu\text{mol.m}^{-2}.\text{s}^{-1}$
 Resolution 0,0001 $\mu\text{mol.m}^{-2}.\text{s}^{-1}$ on range 1.

ii) Illuminance (*Q203 model only*)
 Up to 6 full scale decades measuring from*:
 0 to 1.9999 lux
 0 to 19.999 lux
 0 to 199.99 lux
 0 to 1999.9 lux
 0 to 19999 lux
 0 to 19999 x 10 lux
 Resolution 0,0001 lux on range 1.

iii) Irradiance (*Q203 model only*)
 Up to 6 full scale decades measuring from*:
 0 to 19.999 mW.m^{-2}
 0 to 199.99 mW.m^{-2}
 0 to 1999.9 mW.m^{-2}
 0 to 19.999 W.m^{-2}
 0 to 199.99 W.m^{-2}
 0 to 1999.9 W.m^{-2}
 Resolution 0,001 mW.m^{-2} on range 1.

* Ranges available on request.

Calibration Absolute calibration accuracy $\pm 5\%$ CIE, $\pm 7.5\%$ PAR & RFF, traceable to NPL & BSI standards. Photopic colour correction integrated error of $\pm 1\%$ over visible spectrum.

2 SPECIFICATION (continued):

Front Panel Controls:

<i>RANGE</i>	Select auto ranging or manual range control.
<i>UNITS</i>	Select between PAR ($\mu\text{mol}\cdot\text{m}^{-2}\cdot\text{s}^{-1}$), (m)W.m ⁻² or LUX to match the filter ring fitted to the detector. Select AUX for any special filter rings or accessories if fitted.
<i>ZERO</i>	Initiates a zero or background measurement routine on all five ranges.
<i>HOLD/RUN</i>	Display is held at present reading until HOLD button is pressed again.
<i>MODE</i>	Select to run or hold a special mode. Select between, AVERAGE, MIN, MAX and INTEGRATE modes. Press RESET to return to normal measurement mode.
<i>FUNCTION/RESET</i>	Press to reset function values to zero
<i>RESET</i>	Press to return to normal measurement mode from Manual range control or special modes. Note the display hold is not reset.
⓪	Power on / off button
⊗	Display backlight on off button. Display backlight will switch off after a programmable delay, factory setting 60 secs.
Connectors:	8 pin mini DIN type detector connector. 5 pin mini DIN type RS232 connector.
Temperature Range:	0 to 40°C. 80% RH.
Dimensions:	150 x 80 x 45mm. High impact polystyrene.
Weight:	350g

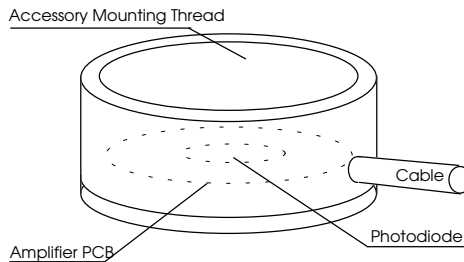
2 SPECIFICATION (continued):**LABORATORY DETECTOR, Model SD222-33**

The SD223 laboratory detector comprises of an aluminium housing, photodiode and PCB assembly.

Detector: 33mm² High stability silicon photodiode.

Responsivity: Excluding filter rings. Figure 1

Temperature Coefficient: <0.3 %/°C

Amplifier Gain 2x10⁸ V/A to 2x10⁴ V/A

Current to Frequency 0 - 0.5Mhz

Linearity Error: <1% across ranges

Temperature Range: Operation: -10 to +60°C
Storage: -20 to +70°C

Detector Housing: Black anodised aluminium alloy housing.
Each optical accessories screws into the detector housing on a 1.125" x 20 T.P.I.

Cable: 1 metre cable to 8 pin mini DIN type connector

2 SPECIFICATION (continued):

Laboratory Detector SD222-33 Responsivity (A/W)

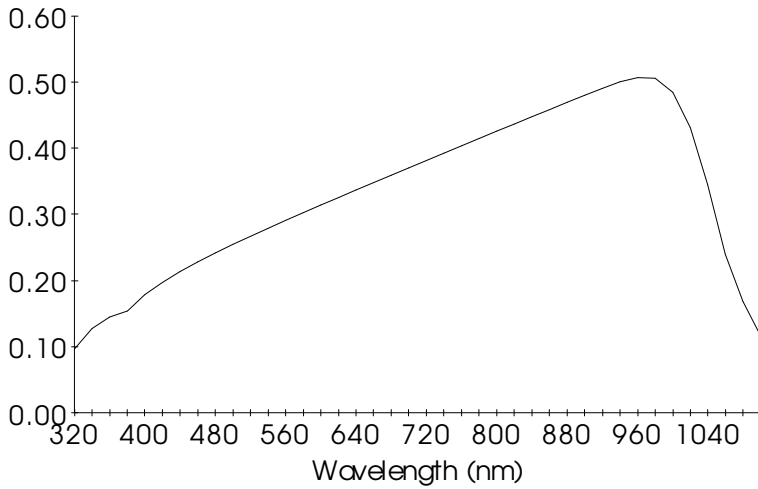
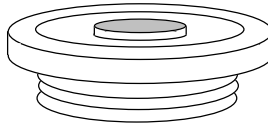

Figure 1

2 SPECIFICATION (continued):

PAR FILTER RING, Model PAR Cos-112



Spectral Response: Refer figure 2.

Angular Response: Accurately cosine corrected to Lambert's Cosine Law. Maximum error is less than $\pm 3.5\%$ from true response to 70° from normal incidence, reference section 7.

Filter ring assembly: Black anodised aluminium alloy ring with screw thread 1.125" x 20 T.P.I. Multiple coloured filter glasses individually selected. Specially profiled diffuser for high accuracy cosine angular response.

PAR Cos-112 Filter Ring with SD222-33 Detector
Typical Spectral response

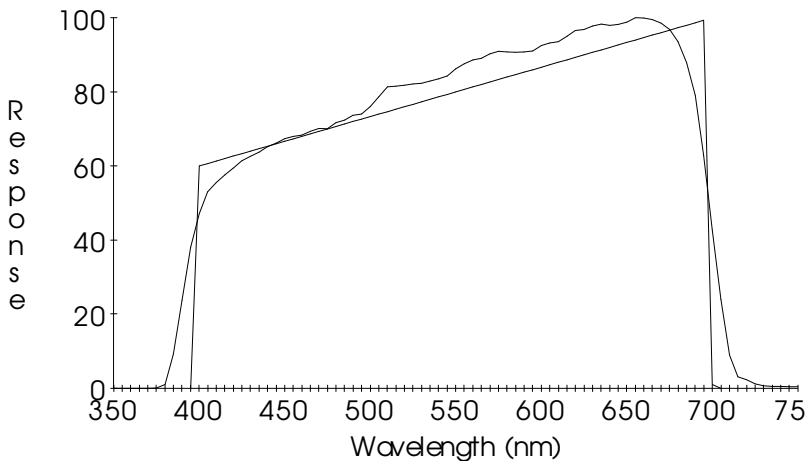
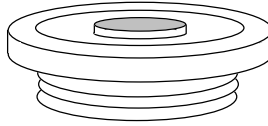

Figure 2

2 SPECIFICATION (continued):

RADIOMETRIC FLAT FILTER RING, Model RFF-Cos-112



Spectral Response: Refer figure 3.

Angular Response: Accurately cosine corrected to Lambert's Cosine Law. Maximum error is less than $\pm 3.5\%$ from true response to 70° from normal incidence, reference section 7.

Filter ring assembly: Black anodised aluminium alloy ring with screw thread 1.125" x 20 T.P.I. Multiple coloured filter glasses individually selected to flatten the silicon photodiode response across the visible and near infrared spectrum. Specially profiled diffuser for high accuracy cosine angular response.

RFF Cos-112 Filter Ring with SD222-33 Detector
Typical Spectral response

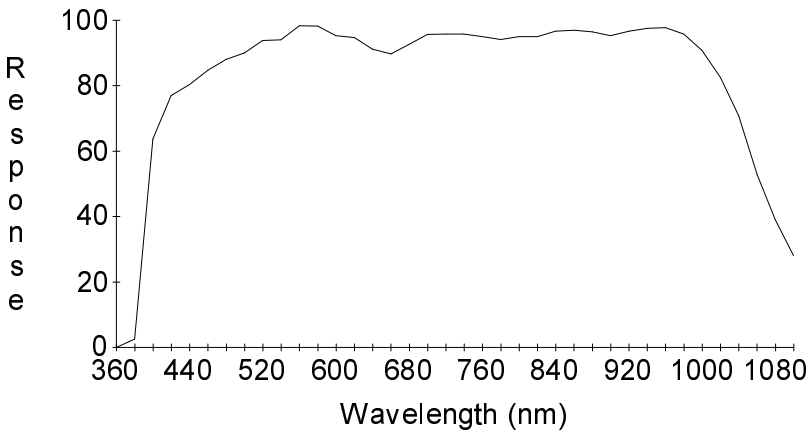
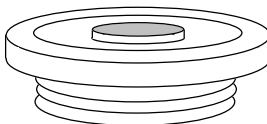

Figure 3

2 SPECIFICATION (continued):

RADIOMETRIC FLAT FILTER RING, Model RFF-VIS-Cos-112



Spectral Response: Refer figure 4.

Angular Response: Accurately cosine corrected to Lambert's Cosine Law. Maximum error is less than $\pm 3.5\%$ from true response to 70° from normal incidence, reference section 7.

Filter ring assembly: Black anodised aluminium alloy ring with screw thread 1.125" x 20 T.P.I. Multiple coloured filter glasses individually selected to flatten the silicon photodiode response across the visible and near infrared spectrum. Specially profiled diffuser for high accuracy cosine angular response.

RFF-VIS Cos-112 Filter Ring with SD222-33 Detector
Typical Spectral response

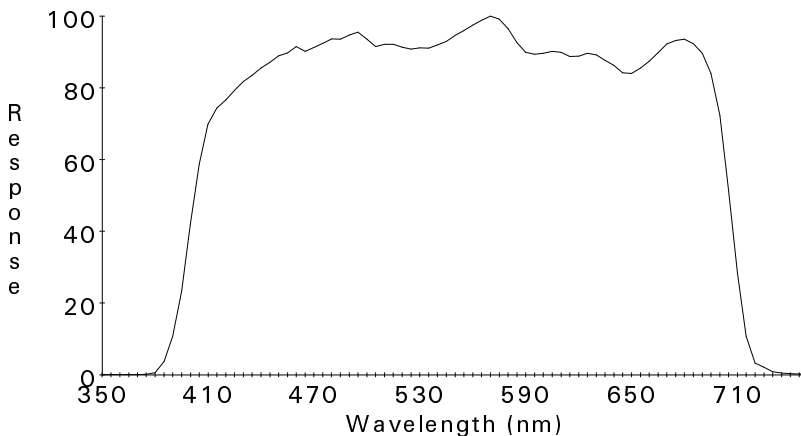
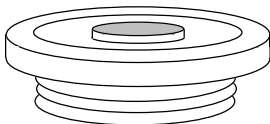

Figure 4

2 SPECIFICATION (continued):

PHOTOPIC FILTER RING, Model CIE-Cos-112



Spectral Response: Refer figure 5.

Angular Response: Accurately cosine corrected to Lamberts Cosine Law. Maximum error is less than $\pm 3.5\%$ from true response to 70° from normal incidence.

Filter ring assembly: Black anodised aluminium alloy ring with screw thread 1.125" x 20 T.P.I.
Multiple coloured filter glasses individually selected for close matching to V_λ .
Specially profiled acrylic diffuser for high accuracy cosine angular response.

CIE Cos-112 Filter Ring with SD222-33 Detector
Typical Spectral response

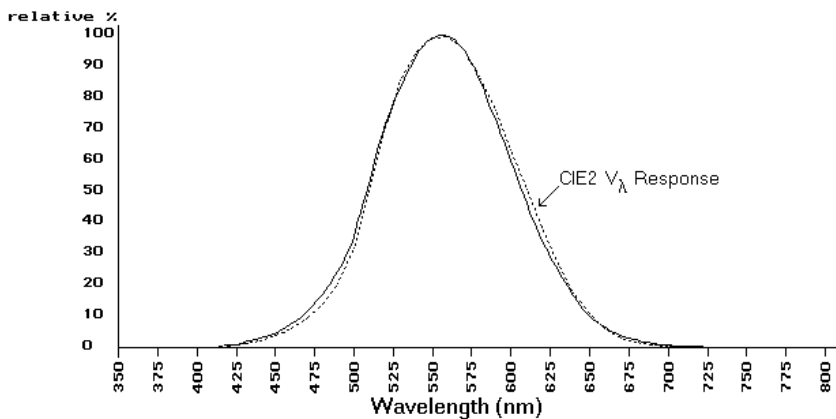
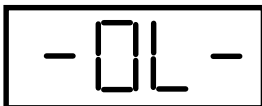

Figure 5

3 OPERATION

SETTING UP

- 1) With the unit OFF, plug the detector 8 way connector into the socket on the top of the display unit.
- 2) Screw a filter ring on to the detector housing. Note: Carefully clean the white diffuser on the filter rings if they are marked or dirty.
- 3) Press and release the power switch on the Q203 display key pad. The micro controller will initiate with the display momentarily showing:-



The radiometer will now search for the optimum range on the detector amplifier. A typical display is shown below.



An LED will illuminate indicating the filter rings calibration, *PAR*, $(m)W.m^{-2}$ or *LUX*. This will be the same filter ring selected prior to the last power off.

- 4) Press and release the *UNITS* switch to select the calibration factor matched to the filter ring fitted to the detector.
- 5) It is recommended that the radiometer amplifier is nulled periodically. Place the cover over the filter ring or the end of the field of view probe. Press and release the *ZERO* switch, the display will momentarily show:-



3 OPERATION (continued)

6) The micro controller will now measure the amplifier offset on each of the five ranges and store these values in the non volatile memory. All subsequent measurements will first have one of these offsets subtracted before displaying the measurement. At the end of the nulling sequence the display will show:-



Note if the radiometer is set to measure illuminance or PAR the display will show *0.0000*.

7) Remove the light cover from the detector. The equipment is now ready for use.

8) AVERAGE

When the light is unstable, press and release the MODE switch. The radiometer will now switch to manual ranging, Manual LED on, if not yet previously in manual ranging. The *Average* LED will now switch on, but the Units LED will remain unchanged.

To start an average sequence press and release the HOLD/RUN switch. Immediately the display will show a fluctuating signal, reflecting the light source fluctuations. After a short time the amplitude of the fluctuations will decrease and the display will begin to show a reading which represents the average light level during the period of the measurement.

At any time the averaging process can be halted by pressing the HOLD/RUN button.

At any time the averaging sequence can be reset by pressing and releasing the FUNCTION RESET switch.

If the light level fluctuations are large and any one reading causes the detector amplifier to overload at this range the averaging process will be terminated and the display will show:-

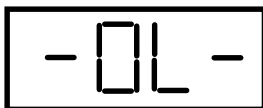

In order to avoid an overload conditions *RESET* the radiometer and Manually change the RANGE to a lower gain. e.g. from a 34.00 range to 34.0.

3 OPERATION (continued)

9) MIN & MAX LEVELS

During an average measurement sequence the maximum and minimum values attained in the period are recorded. Press *HOLD* to halt the averaging sequence. Press the *MODE* button to select between *Average*, *Min* and *Max*. Note the Integrate display may overload and show - 0 L -.

It is also possible to view a *MIN* or *MAX* recording sequence by selecting *MIN* or *MAX* prior to selecting *RUN*.

Press *FUNCTION RESET* to set the maximum and average values to zero and the minimum to - 0 L -. Note the *FUNCTION RESET* will operate during a measurement sequence or in the *HOLD* mode.

10) INTEGRATE

For measurements of the integrated dosage or exposure press the *MODE* switch to select *Integrate*. Press the *RUN* switch to start the measurement. The display will now autorange as the dosage increases.

Note the detector amplifier will not autorange and as with *Average* measurements if the amplifier overloads the display will show - 0 L - and the measurement will halt.

Units for integrated measurements as shown in blue on the radiometer, mJ.m^{-2} and J.m^{-2} .

At the end of the integration period *HOLD* the display. Use the *MODE* switch to also display the *Min*, *Max* and *Average* values.

Press *FUNCTION RESET* to set the integrate, maximum and average values to zero and the minimum to - 0 L -. Note the *FUNCTION RESET* will operate during a measurement sequence or in the *HOLD* mode.

4 PAR MEASUREMENTS (PAR Cos-112 filter ring fitted)

The Q203 radiometer measures the number of quanta (photons) of light between 400nm and 700nm incident on the diffuser input to the detector, per second. Measurement units are $\mu\text{mol.m}^{-2}.\text{s}^{-1}$ (equivalent to $\mu\text{Einstein.m}^{-2}.\text{s}^{-1}$). Conversion to number of photons $1 \mu\text{mol.m}^{-2}.\text{s}^{-1} = 6.02 \times 10^{17} \text{ quanta.m}^{-2}.\text{s}^{-1}$

For most applications the measurement plane is horizontal and a cosine corrected diffuser is fitted to the front of the detector assembly. If the working surface is not horizontal then placing the detector on or parallel to the worktop is a more representative measurement of irradiance.

Note that all the light sources in the hemisphere above the detector will contribute to the measurement. The sources may be obvious, lamps or windows or even walls or other reflecting surfaces. Take care not to shadow the detector during all measurements.

5 IRRADIANCE MEASUREMENTS (*RFF Cos-112 filter ring fitted*) (*RFF-VIS Cos-112 filter ring fitted*)

Irradiance is the measurement of radiometric light per unit area, watts per metre, W/m^2 . The part of the spectrum to be measured is defined by the filter fitted onto the detector. Ideally the filter should have square edges and have a perfectly flat spectral response. With the RFF Cos-112 filter ring fitted the spectral region is typically 400 to 1060nm between the 50% response points (or 400 to 700nm with the RFF-VIS ring fitted)

In all applications it is vital to have some knowledge of the spectrum of the light source. For example a tungsten halogen lamp will have a spectral output similar to a black body source, with most of the output in the infra red region from 1000 to 2500nm and some visible output. A measurement of irradiance of this lamp with the RFF Cos-112 filter ring will only represent a small proportion of the total lamp output (and even less with the RFF-VIS filter ring). Whereas the proportion of measured irradiance to total irradiance from a dichroic filtered tungsten halogen lamp is much higher.

When the Q203 is being used to measure monochromatic sources small adjustments can be made to correct for the non flat response. For example monochromatic light at 650nm will need a +10% adjustment.

As an alternative to single wavelength calibration (ref. Section 8) the radiometer could be calibrated for a particular type of source using a spectroradiometer.

For most applications the measurement plane is horizontal and a cosine corrected diffuser is fitted to the front of the detector assembly. If the working surface is not horizontal then placing the detector on or parallel to the worktop is a more representative measurement of irradiance.

Note that all the light sources in the hemisphere above the detector will contribute to the measurement. The sources may be obvious, lamps or windows or even walls or other reflecting surfaces. Take care not to shadow the detector during all measurements.

Both RFF filter rings are cosine corrected (ref section 7). Measurement errors will increase as the angle of irradiance increases from the normal to the filter ring front surface.

6 ILLUMINANCE MEASUREMENTS (*CIE Cos-112 filter ring fitted*)

Illuminance is the measurement of photometric light per unit area, lumens per metre, Lux, or lumens per square foot, footcandle. For most applications the measurement plane is horizontal and a cosine corrected diffuser is fitted to the front of the detector assembly. If the working surface is not horizontal then placing the detector on or parallel to the worktop is a more representative measurement of the illuminance.

Note that all the light sources in the hemisphere above the detector will contribute to the illuminance measurement. The sources may be obvious, lamps or windows or even walls or other reflecting surfaces. Take care not to shadow the detector during all illuminance measurements.

- 1) Set up the photometer as outlined in section 3 with the illuminance filter ring fitted and the units set to either Lux or fc.
- 2) Place the detector at the measuring point and record the value on the display. If the light levels are low it may be necessary to switch on the display back light.
- 3) The display can be read directly for all light levels from 0.0000 Lux to 19 999 Lux. Note however that for illuminance values of 20 000 to 199 990 Lux, the x10 LED will illuminate and the displayed value must be multiplied by 10.

CONVERSION FACTORS

1 Lux	=	0.0929 footcandle
1 Lux	=	1 candela @ 1 metre
1 Lux	=	d ² candela @ d metres

7 COSINE ANGULAR RESPONSE

Irradiance is a measurement of the amount of light incident on a unit area (Watts.m^{-2}). Any detector will measure this reliably when measuring a beam of light perpendicular to the detectors surface, however, when measuring scattered light or light from an extended source the sensor must have an accurate response over its 180° field of view. More importantly, this response should be proportional to the cosine of the angle of light incident on the detector. This comes from the fact that the projected area of any surface at an angle of i is proportional to $\cos(i)$.

To ensure that the integration of light from all angles is correct, the cosine diffuser matches the angular response so that response of the detector decreases with $\cos(i)$ as the angle between the source and detector increases from 0 to 90° .

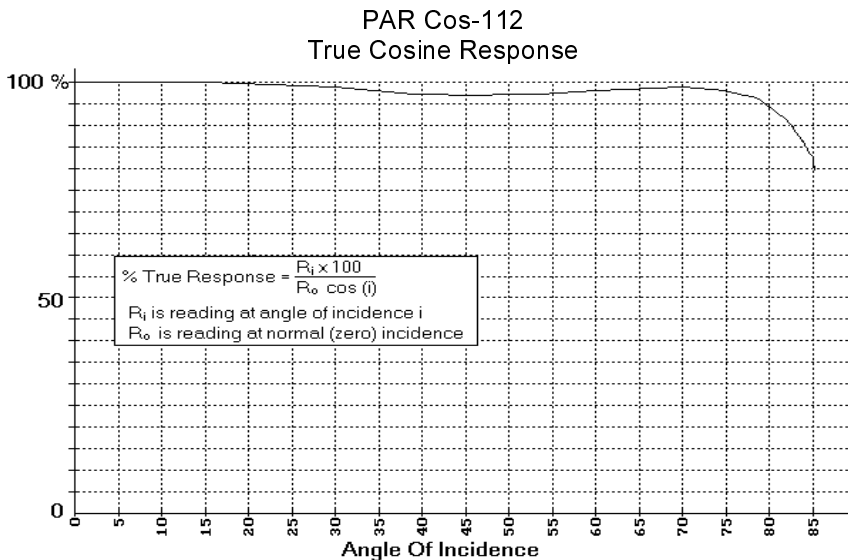

Figure 6

Macam's cosine diffusers are corrected to match the cosine response to within $\pm 3.5\%$ up to angles of 70° . This ensures that the meter correctly reads illuminance or visible light flux density whether it is measuring light from an extended or a point source.

8 CALIBRATION DESCRIPTION

Macam Photometrics hold a number of tungsten halogen and deuterium lamps and silicon photodiodes which are routinely calibrated by the National Physics Laboratory and the British Standards Institute in the UK.

PAR Calibration is carried out using a solar simulated uniform source and Macam Spectroradiometer.

Photometric calibration uses an Illuminant A source.

Radiometric calibration is carried out with a monochromatic source.

During manufacture each filter ring and detector has its spectral response measured. Changes are made to the filter glasses if the peak wavelength or filter bandwidth exceed the specification limits. A graph of the final filter/detector response is provided. The data on a disk (IBM PC format) is also available on request for importing to a spreadsheet.

As with all measuring equipment a routine calibration is recommended, typically annually, but with frequent use by a number of different users a shorter recalibration period may be necessary.

Contact Macam for any calibration requirements for this product and for further information.

9 CARE AND MAINTENANCE

- 1) The Q203 display unit can be cleaned using a moist cloth with detergent. Do not use solvent or alcohol to clean surfaces.
- 2) The diffuser on each filter ring should be kept clean at all times.
- 3) The radiometer is a precision instrument, protect from shocks.
- 4) Avoid supporting the detector by the multi core cable.

10 OPTIONAL ACCESSORIES

The following items are available from Macam:

Levelling Plate (Three adjustable feet and built in spirit bubble)
Waterproof Cosine and 4π detectors
Extension cable
Sample PC Software.

11 BLOCK DIAGRAM

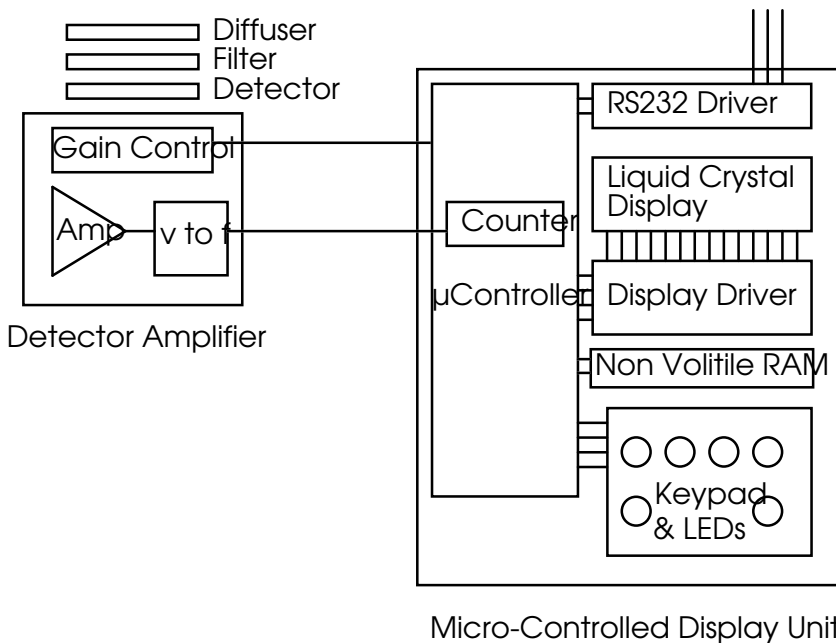

12PROGRAMMING VIA THE RS232 INTERFACE

Serial Port Settings: 4800 baud, no handshaking

Single letter commands

- S Toggle through possible gain ranges (manual mode)
Reset to autorange with R command.
- U Toggle through possible units, PAR, (m)W.m⁻², Lux & Aux
- F Toggle through possible functions
- I Function reset
- H Toggles hold/go
- Z Zeros light meter
- R Resets light meter
- B Toggles backlight
- s Sends data continuously via the RS232
- o Sends one set of data via the RS232

12 PROGRAMMING VIA THE RS232 INTERFACE (continued)

12.1 Windows 3.1 & Windows 95

Setting up remote control via Microsoft TERMINAL.EXE

1. Connect the cable between the RS232 socket on the light meter and the COM port on the PC.
2. Switch on the light meter.
3. Run *Terminal* programme.
4. Go to the *Settings / Communications* screen and set the baud to 4800 and the COM port to suit.
5. Go to the *Settings / Text Transfers* and select *Line at a time with 1/10th second delay*.
6. Check the RS232 link by a switch to the manual range, LED on using the command 'S', (capital S).
7. Reset to the auto range, LED off using the command 'R', (capital R).
8. Type 'o' for one packet of data and 's' for continuous data. Type 's' to stop the data flow.
9. To save the terminal setup go to *File / Save As* and save the settings. When restarting the programme the settings can be reloaded with *File / Load filename*. Now actions 4 and 5 can be omitted.

Logging data continuously to a file using Microsoft TERMINAL.EXE

1. Run the Terminal programme with the correct settings.
2. Set up the radiometer and send the command 's' via Terminal to transmit data continuously from the radiometer.
3. Go to *Transfers / Receive Text File*. Enter filename for the stored data (e.g. log1.txt).
4. On entering the file name, Terminal will now store all the readings transmitted from the radiometer in a file *log1.txt*. The file is saved to the computer by pressing STOP on the terminal screen.

12 PROGRAMMING VIA THE RS232 INTERFACE (continued)

12.2 Windows 95 & Windows 98

Setting up remote control via Microsoft HYPERTERMINAL.EXE

1. Connect the cable between the RS232 socket on the light meter and the COM port on the PC.
2. Switch on the light meter.
3. Run the *HyperTerminal* programme.
4. Enter a name for the session (e.g. Q203 etc.).
5. Select the type of connection required, either option 'direct to com 1' or 'direct to com 2' depending on which com port is to be used.
6. Enter the details for the serial connection: 4800 bits per second, 8 data bits, no parity, 1 stop bit and no flow control.
7. Click the properties icon or select via the *File / Properties* option to display the properties window.
8. Select the *Settings* tab and select Auto detect for the *Emulation* setting.
9. Click the *ASCII Setup* button. Enter 100 into the box marked *Line delay*. No other options are necessary. Click on OK to return to the main window.
10. Check the RS232 link by downloading a reading using the command 'o', (lowercase o). This also allows auto detect to correctly identify the meter settings, showing 4800 8-N-1 next to the Auto detect message in the status bar. A reading should appear in the main window if the connection has been made successfully.
11. To save the terminal setup go to *File / Save As* and save settings. When restarting the programme the settings can be loaded directly by double-clicking on the *.ht icon that has been created. Now actions 4 to 9 can be omitted.

12 PROGRAMMING VIA THE RS232 INTERFACE (continued)

Logging data to a file using Microsoft HYPERTERMINAL.EXE

1. Run the HyperTerminal programme with the correct settings.
2. Set up the radiometer and send the command 's' via HyperTerminal to transmit data continuously from the radiometer.
3. Go to *Transfer / Capture Text*. Enter the filename for the stored data and the location to save to. (e.g. C:\HyperTerminal\Capture.txt).
4. Press the *start* button to store all the readings transmitted from the radiometer in a file *Capture.txt*. The status bar will now show a highlighted 'Capture' message. The file is saved to the computer by selecting *Transfer / Capture Text / Stop*.
5. Send the command 's' again via HyperTerminal to stop the continuous transmission of data from the radiometer.

Macam Photometrics Ltd.
10 Kelvin Square
Houstoun Industrial Estate
Livingston
Scotland EH54 5PF

Telephone: 01506 437-391
Facsimile: 01506 438-543
E-mail: info@macam.com
Web: www.macam.com