

**DIGITAL PHOTOMETER**  
**MODELS L203 & L203 Lux**  
**HANDBOOK**

Contents:	1 Introduction
	2 Specification
	3 Operation
	4 Illuminance Measurements
	5 Luminance Measurements
	6 Battery Replacement
	7 Photopic Response
	8 Cosine Angular Response
	9 Calibration Description
	10 Block Diagram
	11 Programming via the RS232 Interface

Handbook Ref No.	MH063/Issue G
File Ref:	L203-v5g.wps

Handbook Update Log

<u>Issue</u>	<u>Date</u>	<u>Pages changed</u>
A	19/03/99	New Issue
B	19/12/99	Update for V4 programming
C	14/06/00	4,6,11,13,19-25: Update for V5 programming
D	04/01/01	Version 5 update
E	06/02/02	20: Programming update
F	22/05/02	8: CRT head update
G	23/02/06	7,17: Cosine response update

## 1 INTRODUCTION

The Macam L203 Digital Photometer is a portable instrument designed for accurate measurement of luminous incidence or illuminance in Lux (fc, foot-candle) and luminous intensity or luminance in  $\text{cd.m}^{-2}$ , candela per square metre (fL, foot-Lambert). The model L203-Lux is available for illuminance measurements only.

The photometers comprise of a hand held display unit, a detector /amplifier assembly with connecting cable, an illuminance filter ring and a luminance field of view probe. The sensor is a large area silicon photodiode with excellent linearity and long term stability. The Macam photopic filter ring and photopic field of view probe, fitted to the front of the silicon detector give a response which closely matches the human eye response outlined by the CIE  $V\lambda$  curve. This precise colour correction gives high accuracy of photometric measurements from light sources with different spectral distributions (see Calibration section).

For illuminance measurements, the Macam photopic filter ring with cosine corrected diffuser (model CIE Cos-112) is fitted to the detector assembly. This will integrate light from all sources in the hemisphere in front of the detector. Before leaving the factory, the instrument is calibrated to read directly in Lux and fc (foot-candle).

The L203 Photometer can also measure luminance directly. In this mode of operation, the illuminance filter ring is removed from the detector assembly and replaced with either a CIE FOV-112 luminance probe (with a defined field-of-view of  $6^\circ$ ) or a contact CIE FOV-101 CRT luminance probe. In either case, where the luminance varies across the field of view or probe area, the meter reading will represent the average luminance. The photometer can measure in either  $\text{cd.m}^{-2}$  and fL (foot-Lambert).

**2 SPECIFICATION:****DISPLAY UNIT**

Controller:	80C51 8bit micro-processor with a 3.1684MHz clock.	
Memory	On board non volatile RAM for calibration factors and set-up parameters.	
Key Operation	8 switch key board with 11 LED indicators.	
Power Switch	Microprocessor reset at switch on. Unit settings stored prior to shut down.	
Serial Interface	Three wire RS232 serial interface. 4800 baud, no parity, 1 stop bit.	
Integration Time	0.33s	
Conversion Scale	17 bit	
Accuracy:	Measurement accuracy $\pm 1$ digit with a linearity error of <1% from 1 to 100 000 Lux.	
Display:	4½ digit lcd display. Character height 10mm.	
Display illumination:	A LED back light can be switched on to illuminate the display for readings in low ambient light situations.	
Power Supply:	9 volt 1200mAh, Lithium Manganese battery.	
Power Consumption:	Shut down mode	<5µA
	Operating	10 - 20mA
	LED back light	~20mA
Battery Life	~ 50 hours without backlight use	

**2 SPECIFICATION (continued):**

Ranges:

i) Illuminance (*both models*)  
 Up to 6 full scale decades measuring from:  
 0 to 1.9999 lux  
 0 to 19.999 lux  
 0 to 199.99 lux  
 0 to 1999.9 lux  
 0 to 19999 lux  
 0 to 19999 x 10 lux  
 Resolution 0,0001 lux on range 1.

Up to 5 full scale decades measuring from:  
 0 to 1.9999 fc  
 0 to 19.999 fc  
 0 to 199.99 fc  
 0 to 1999.9 fc  
 0 to 19999 fc  
 Resolution 0,0001 fc on range 1.

ii) Luminance (*model L203 only*)  
 Up to 6\* full scale decades measuring from:  
 0 to 1.9999 cd.m<sup>-2</sup> (\*with CIE-FOV-112 only)  
 0 to 19.999 cd.m<sup>-2</sup>  
 0 to 199.99 cd.m<sup>-2</sup>  
 0 to 1999.9 cd.m<sup>-2</sup>  
 0 to 19999 cd.m<sup>-2</sup>  
 0 to 19999 x 10 cd.m<sup>-2</sup>  
 Resolution 0,0001 cd.m<sup>-2</sup> on range 1\*.  
 Resolution 0,001 cd.m<sup>-2</sup> (*with CIE-FOV-101*).

Up to 6 full scale decades measuring from:  
 0 to 1.9999 fL  
 0 to 19.999 fL  
 0 to 199.99 fL  
 0 to 1999.9 fL  
 0 to 19999 fL  
 0 to 19999 x 10 fL  
 Resolution 0,0001 fL on range 1.

Calibration Absolute calibration accuracy ±5% traceable to NPL standards.  
 Photopic colour correction integrated error of ±1% over visible spectrum.

**2 SPECIFICATION (continued):**

Front Panel Controls:

<i>RANGE</i>	Select auto ranging or manual range control.
<i>UNITS</i>	Select between Lux and fc for illuminance measurements and between cd.m <sup>-2</sup> and fL for luminance measurements. Select AUX for additional accessory calibration if fitted.
<i>ZERO</i>	Initiates a zero or background measurement routine on all gain ranges.
<i>HOLD/RUN</i>	Display is held at present reading until HOLD button is pressed again.
<i>MODE</i>	Select to run or hold a special mode. Select between AVERAGE, MIN, MAX and INTEGRATE modes.
<i>FUNCTION/RESET</i>	Press to reset function values to zero
<i>RESET</i>	Press to return to normal measurement mode from Manual range mode or special modes. Note the display hold is not reset.
⓪	Power on / off button
⊗	Display backlight on off button. Display backlight will switch off after a programmable delay, factory setting 60 secs.

Connectors: 8 pin DIN type detector connector.  
5 pin DIN type RS232 connector.

Temperature Range: 0 to 40°C. 80% RH.

Dimensions: 150 x 80 x 45mm.  
High impact polystyrene.

Weight: 350g

**2 SPECIFICATION (continued):**

**LABORATORY DETECTOR, Model SD222**

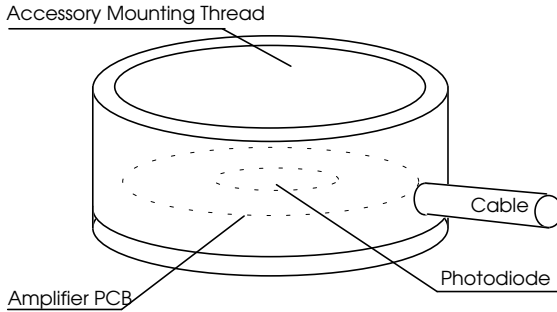

The SD222 laboratory detector comprises of a aluminium housing, photodiode and PCB assembly.

Detector: 33mm<sup>2</sup> silicon photodiode.

Temperature Coefficient: -0.10 %/°C

Amplifier Gain 10<sup>9</sup> V/A to 10<sup>3</sup> V/A

Current to Frequency 0 - 0.5Mhz

Linearity Error: <1% from 1 to 100 000 Lux

Temperature Range: Operation: -20 to +60°C  
Storage: -20 to +70°C

Detector Housing: Black anodised aluminium alloy housing.  
Each optical accessories screws into the detector housing on a 1.125" x 20 T.P.I.  
The detector amplifier is connected to the display unit via a multicore cable to a eight pin DIN type connector.

**2 SPECIFICATION (continued):**

## PHOTOPIC FILTER RING, Model CIE Cos-112

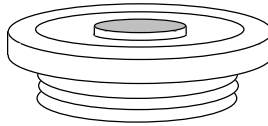

Spectral Response: Refer figure 1 and section 7.

Angular Response: Illuminance measurements  
Accurately cosine corrected to Lambert's Cosine Law. Maximum error is less than  $\pm 3.5\%$  from true response to  $70^\circ$  from normal incidence, reference figure 2.

Filter ring assembly: Black anodised aluminium alloy ring with screw thread 1.125" x 20 T.P.I.  
Multiple coloured filter glasses individually selected for close matching to  $V_\lambda$ ..  
Specially profiled acrylic diffuser for high accuracy cosine angular response.

## FIELD OF VIEW PROBE CIE FOV-112

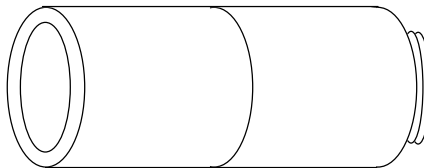

Spectral Response: Refer figure 1 and section 7.

Angular Response: Luminance *measurements (model L203 only)*  
The field of view is defined with FOV1 accessory to  $6^\circ$  full angle.

FOV probe assembly: Black anodised aluminium alloy body with screw thread 1.125" x 20 T.P.I.  
Glass lens f/l 100mm, 25mm  $\phi$  .

**2 SPECIFICATION (continued):**

**CRT SCREEN LUMINANCE PROBE CIE FOV-101**

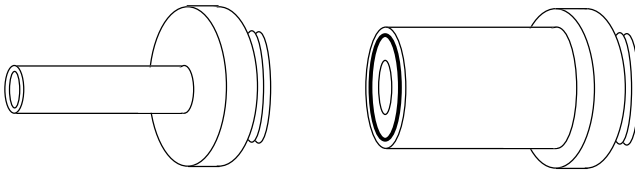

**Spectral Response:** Refer figure 1 and section 7.

**Design:** Aluminium tube; 10 mm internal diameter with aperture, 24 mm (or 18 mm) external diameter. Rubber O-ring tip.

**Screw thread:** 1"1/8 x 20TPI.

### 3 OPERATION

#### SETTING UP

1) With the unit OFF, plug the detector 8 way connector into the socket on the top of the display unit.

2) Carefully screw the filter ring for illuminance measurements, field of view or contact probe for luminance measurements to the detector housing. Note: Clean the white diffuser on the filter ring or the lens on the field of view probe if they are marked or dirty.

3) Press and release the power switch on the L203 display key pad. The micro controller will initiate with the display momentarily showing:-



The photometer will now search for the optimum range on the detector amplifier. A typical display is shown below.



An LED will illuminate indicating the units. This will be the same units prior to the last power off.

4) Press and release the *UNITS* switch to select the correct units required. For illuminance measurements with the CIE Cos-112 photopic filter rings the correct units are either Lux or fc. For luminance measurements with the CIE FOV-112 photopic field of view or contact probe the correct units are either cd.m<sup>-2</sup> or fL.

5) It is recommended that the photometer amplifier is nulled periodically. Place the cover over the filter ring or the end of the field of view or contact probe. Press and release the *ZERO* switch, the display will momentarily show:-



**3 OPERATION (continued):**

6) The micro controller will now measure the amplifier offset on each of the five ranges and store these values in the non volatile memory. All subsequent measurements will first have one of these offsets subtracted before displaying the measurement. At the end of the nulling sequence the display will show:-



Note if the photometer units is set to fc the display will show .0000

7) Remove the light cover from the detector. The equipment is now ready for use.

**8) AVERAGE**

When the light is unstable, press and release the MODE switch. The photometer will now switch to manual ranging, Manual LED on, if not yet previously in manual ranging. The Average LED will now switch on, but the Units LED will remain unchanged.

To start an average sequence press and release the HOLD/RUN switch. Immediately the display will show a fluctuating signal, reflecting the light source fluctuations. After a short time the amplitude of the fluctuations will decrease and the display will begin to show a reading which represents the average light level during the period of the measurement.

At any time the averaging process can be halted by pressing the HOLD/RUN button.

At any time the averaging sequence can be reset by pressing and releasing the FUNCTION RESET switch.

If the light level fluctuations are large and any one reading causes the detector amplifier to overload at this range the averaging process will be terminated and the display will show:-



In order to avoid an overload conditions RESET the photometer and Manually change the RANGE to a lower lever. eg from a 34.00 range to 34.0.

**3 OPERATION (continued):****9) MIN & MAX LEVELS**

During an average measurement sequence the maximum and minimum values attained in the period are recorded. Press *HOLD* to halt the averaging sequence. Press the *MODE* button to select between *Average*, *Min* and *Max*. Note the Integrate display may overload and show - 0 L -.

It is also possible to view a *MIN* or *MAX* recording sequence by selecting *MIN* or *MAX* prior to selecting *RUN*.

Press *FUNCTION RESET* to set the maximum and average values to zero and the minimum to - 0 L -. Note the *FUNCTION RESET* will operate during a measurement sequence or in the *HOLD* mode.

**10) INTEGRATE**

For measurements of the integrated dosage or exposure press the *MODE* switch to select *Integrate*. Press the *RUN* switch to start the measurement. The display will now autorange as the dosage increases.

Note the detector amplifier will not autorange and as with *Average* measurements if the amplifier overloads the display will show - 0 L - and the measurement will halt.

Units for integrated measurements are Lux seconds (Lux.s) footcandle seconds (fc.s),  $\text{cd.m}^{-2}.\text{s}$  and footLambert seconds (fL.s).

At the end of the integration period *HOLD* the display. Use the *MODE* switch to also display the *Min*, *Max* and *Average* values.

Press *FUNCTION RESET* to set the integrate, maximum and average values to zero and the minimum to - 0 L -. Note the *FUNCTION RESET* will operate during a measurement sequence or in the *HOLD* mode.

#### **4 ILLUMINANCE MEASUREMENTS (CIE Cos-112 filter ring fitted)**

Illuminance is the measurement of photometric light per unit area, lumens per metre, Lux, or lumens per square foot, footcandle. For most applications the measurement plane is horizontal and a cosine corrected diffuser is fitted to the front of the detector assembly. If the working surface is not horizontal then placing the detector on or parallel to the worktop is a more representative measurement of the illuminance.

Note that all the light sources in the hemisphere above the detector will contribute to the illuminance measurement. The sources may be obvious, lamps or windows or even walls or other reflecting surfaces. Take care not to shadow the detector during all illuminance measurements.

- 1) Set up the photometer as outlined in section 3 with the illuminance filter ring fitted and the units set to either Lux or fc.
- 2) Place the detector at the measuring point and record the value on the display. If the light levels are low it may be necessary to switch on the display back light.
- 3) The display can be read directly for light levels from 0.0000 Lux to 199 990 Lux or 0.0000 to 19 999 fc. Note however that for illuminance values of 20 000 to 199 990 Lux, the x10 LED will illuminate and the displayed value must be multiplied by 10.

#### **CONVERSION FACTORS**

1 Lux	=	0.0929 footcandle
1 Lux	=	1 candela @ 1 metre
1 Lux	=	d <sup>2</sup> candela @ d metres

## 5 LUMINANCE MEASUREMENTS (CIE FOV-112/101 probe fitted)

Luminance (lumens per steradian per unit area) or brightness is the photometric measurement of the response from viewing an illuminated object or self luminous source.

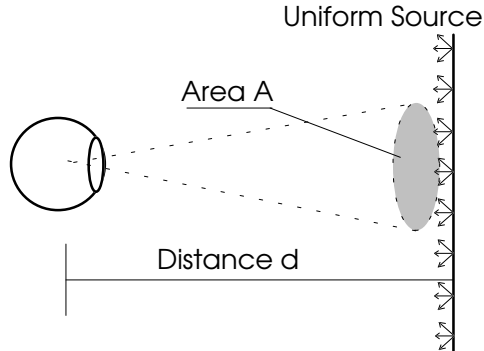

Unit solid angle, steradian =  $A/d^2$

Luminance can be expressed in candela (lumens per steradian) per unit area,  $\text{cd.m}^{-2}$  (also known as nit) or  $\text{cd.cm}^{-2}$  or  $\text{cd.ft}^{-2}$ .

Using the expression below, luminance,  $L$ , can be calculated by measuring the illuminance,  $E$ , on a surface and knowing the reflectance,  $\rho$ , of the surface.

$$\begin{aligned}
 L &= (E * \rho) / \pi \quad \text{where } \pi \text{ is expressed in steradians} \\
 &= (x * \rho) \text{ lm. m}^{-2} / \pi \\
 &= (x * \rho / \pi) \text{ lm. str}^{-1} \cdot \text{m}^{-2} \\
 &= (x * \rho / \pi) \text{ cd.m}^{-2}
 \end{aligned}$$

eg. Calculate the luminance of a surface with a diffuse reflectance of  $\rho = 0.9$  when illuminated at a level of 100 Lux.

$$L = (100 * 0.9 / 3.14) \text{ cd.m}^{-2} = 28.7 \text{ cd.m}^{-2}$$

Luminance can also be expressed as footLambert,  $\text{fL}$ . This unit incorporates the  $\pi$  value and thus provides a simple relationship between the illuminance of a surface of reflectance  $\rho$  and the luminance of the surface.

$$1 \text{ footLambert} = 1 * \rho \text{ footcandles}$$

## 5 LUMINANCE MEASUREMENTS (*continued*)

### MEASURING LUMINANCE WITH THE L203 & THE FOV-CIE-112/101

Measuring luminance requires either the field of view probe and detector / filter combination to be pointed at a radiating surface or extended source, or the crt contact probe and detector / filter combination to be in contact with a radiating surface or extended source. The field of view probe will measure the average luminance within the area subtended by its 6° field of view whereas the contact probe will average over the contact area. For small area measurement with the field of view it will be necessary to bring the probe close to the surface. Care must be taken not to shadow the surface with the probe or yourself if the surface luminance is produced by predominantly reflected light.

Luminance is independent of the measuring distance for a uniform Lambertian infinite sized source, because the sampled area increase cancels the inverse square law losses.

For luminance measurements of small areas it may be preferable to use the Macam Spot measuring Unit model SMU 203 as the reflex viewing optics allows the user to determine the precise measurement area.

- 1) Set up the photometer as outlined in section 3 with either luminance probe fitted and the units set to either  $\text{cd.m}^{-2}$  or fL.
- 2) Point the detector at the reflecting surface or self luminous source or press the contact probe squarely and firmly onto the surface and record the value on the display.
- 3) The display can be read directly for all light levels from 0.0000\* to 199 990  $\text{cd.m}^{-2}$  or fL (*\*with CIE-FOV-112 only*). Note for luminance values of 20 000 to 199 990  $\text{cd.m}^{-2}$  or fL, the x10 LED will illuminate and the displayed value must be multiplied by 10.

### CONVERSION FACTORS

$$1 \text{ cd.m}^{-2} \quad = \quad 0.292 \text{ footLamberts}$$

## **6 BATTERY REPLACEMENT**

- 1) Switch off the photometer before changing the battery.
- 2) Slide open the battery compartment on the back of the photometer and pull out the battery. Disconnect from the battery clip
- 3) Replace with a Lithium Manganese size PP3 9 volt battery.
- 4) Place battery inside compartment and slide cover closed.
- 5) Note it will be necessary to switch on and off the photometer before normal operation will commence.

## 7 PHOTOPIC RESPONSE

Photometry is the measurement of visible light. Macam's photopic filter and photodiode closely matches the response of the standard human eye as published by the CIE (CIE  $V_\lambda$ ). The spectral response of the photodiode detector with the photopic filter ring is plotted beside the ideal CIE response.

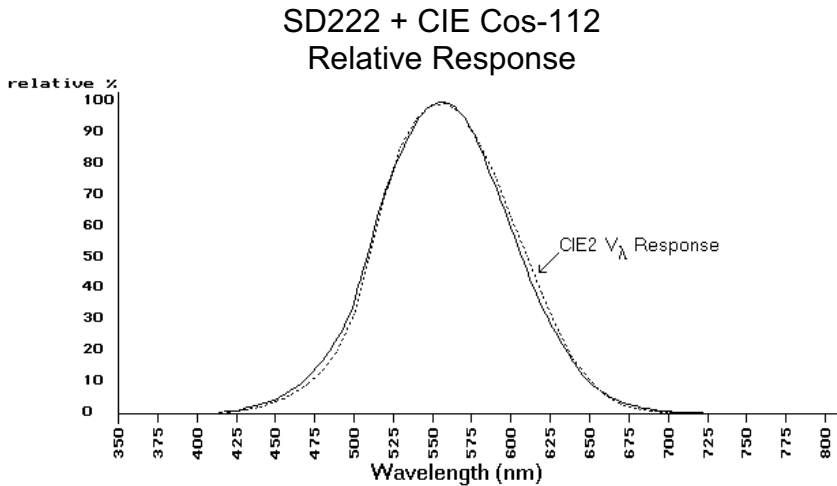

Figure 1

Photometers which do not closely match the response are often supplied with correction factors for different types of lamps and light sources. This means that the user has to identify the type of source being measured and correct the meter reading. This procedure becomes more unreliable when sources are mixed for example office lighting mixed with daylight through a window.

The response of the Macam photometer is such that the error for a wide variety of sources is typically < 2%.

### 8 COSINE ANGULAR RESPONSE

Illuminance is a measurement of visible light incident on a unit area (Lumens/m<sup>2</sup>). A detector will measure this reliably when the light beam is perpendicular to the detector's surface. Accurate measurements of illuminance require that the detector should respond to light over a 180° field of view. More importantly, this response should be proportional to the cosine of the angle of light incident on the detector. To ensure that the integration of light from all angles is correct, the cosine diffuser fitted to the front of the filter ring is profiled such that the angular response of the detector decreases with cos(i) as the angle between the source and detector increases from 0 to 90°.

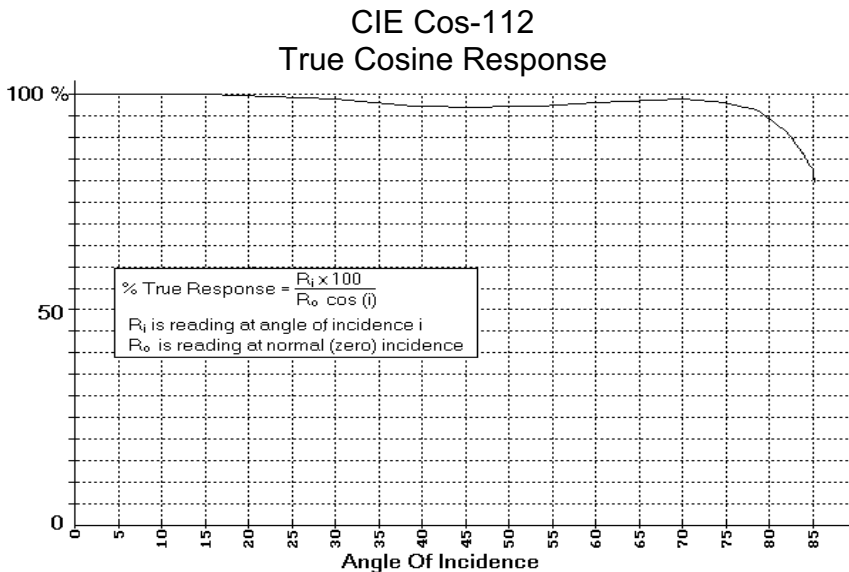

Macam's cosine diffusers are corrected to match the cosine response to within ±3.5% up to angles of 75°. This ensures that the meter correctly reads illuminance or visible light flux density whether it is measuring scattered light (from an overcast sky) or a point source (a single lamp in a dark room).

## 9 CALIBRATION DESCRIPTION

Macam Photometrics hold a number of tungsten halogen lamps, photometers and a silicon photodiodes which are routinely calibrated by the National Physics Laboratory in the UK.

During manufacture each photopic filter is scanned for the best match to the CIE response. A graph of the final filter/detector response is provided. The data on a disk (IBM PC format) is also available on request for importing to a spreadsheet.

The photometer is calibrated for illuminance using a lamp of colour temperature 2855K  $\pm$ 10K and for luminance using a highly uniform integrating sphere source of colour temperature 2600K  $\pm$ 10K.

Macam estimate the absolute accuracy error in calibration of each L203 and L203 Lux photometers is  $\pm$ 5% for a source of illuminant A at normal incidence. The errors mentioned in sections 7 and 8 namely spectral response and cosine angular error are small for most applications.

As with all measuring equipment a routine calibration is recommended, typically annually, but with frequent use by a number of different users a shorter recalibration period may be necessary.

Contact Macam for any calibration requirements for this product and for further information.

### 10 BLOCK DIAGRAM

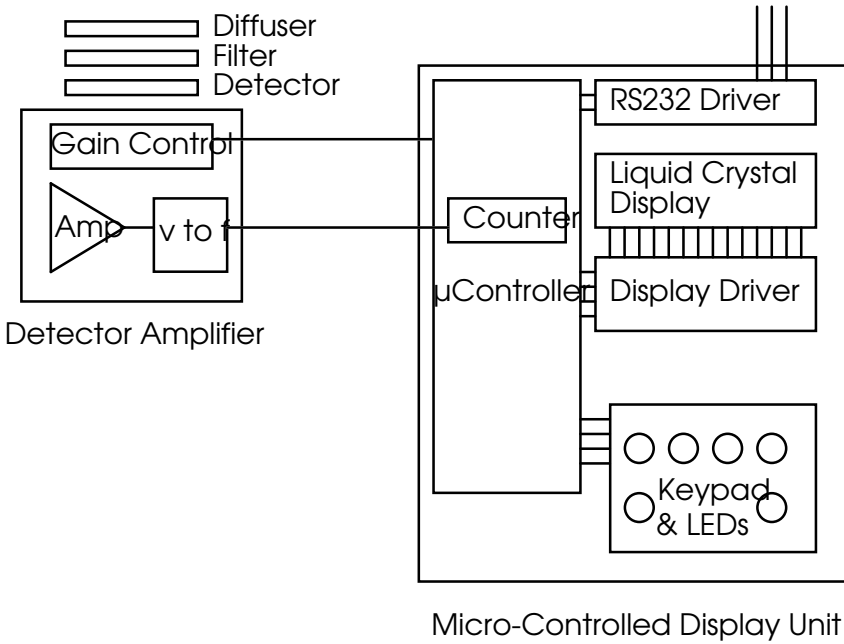

**11 PROGRAMMING VIA THE RS232 INTERFACE**

Serial Port Settings: 4800 baud, no handshaking

Single letter commands

- S Toggle through possible gain ranges (manual mode)  
Reset to autorange with R command.
- U Toggle through possible units, Lux, fc, etc., as applicable
- F Toggle through possible functions
- I Function reset
- H Toggles hold/go
- Z Zeros light meter
- R Resets light meter
- B Toggles backlight
- s Sends data continuously via the RS232
- o Sends one set of data via the RS232

**11 PROGRAMMING VIA THE RS232 INTERFACE** (continued)

## 11.1 Windows 3.1 &amp; Windows 95

## Setting up remote control via Microsoft TERMINAL.EXE

1. Connect the cable between the RS232 socket on the light meter and the COM port on the PC.
2. Switch on the light meter.
3. Run *Terminal* programme.
4. Go to the *Settings / Communications* screen and set the baud to 4800 and the COM port to suit.
5. Go to the *Settings / Text Transfers* and select *Line at a time with 1/10th second delay*.
6. Check the RS232 link by a switch to the manual range, LED on using the command 'S', (capital S).
7. Reset to the auto range, LED off using the command 'R', (capital R).
8. Type 'o' for one packet of data and 's' for continuous data. Type 's' to stop the data flow.
9. To save the terminal setup go to *File / Save As* and save the settings. When restarting the programme the settings can be reloaded with *File / Load filename*. Now actions 4 and 5 can be omitted.

## Logging data continuously to a file using Microsoft TERMINAL.EXE

1. Run the Terminal programme with the correct settings.
2. Set up the radiometer and send the command 's' via Terminal to transmit data continuously from the radiometer.
3. Go to *Transfers / Receive Text File*. Enter filename for the stored data (e.g. log1.txt).
4. On entering the file name, Terminal will now store all the readings transmitted from the radiometer in a file *log1.txt*. The file is saved to the computer by pressing STOP on the terminal screen.

**11 PROGRAMMING VIA THE RS232 INTERFACE** (continued)

## 11.2 Windows 95 &amp; Windows 98

## Setting up remote control via Microsoft HYPERTERMINAL.EXE

1. Connect the cable between the RS232 socket on the light meter and the COM port on the PC.
2. Switch on the light meter.
3. Run the *HyperTerminal* programme.
4. Enter a name for the session (e.g. L203 etc.).
5. Select the type of connection required, either option 'direct to com 1' or 'direct to com 2' depending on which com port is to be used.
6. Enter the details for the serial connection: 4800 bits per second, 8 data bits, no parity, 1 stop bit and no flow control.
7. Click the properties icon or select via the *File / Properties* option to display the properties window.
8. Select the *Settings* tab and select Auto detect for the *Emulation* setting.
9. Click the *ASCII Setup* button. Enter 100 into the box marked *Line delay*. No other options are necessary. Click on OK to return to the main window.
10. Check the RS232 link by downloading a reading using the command 'o', (lowercase o). This also allows auto detect to correctly identify the meter settings, showing 4800 8-N-1 next to the Auto detect message in the status bar. A reading should appear in the main window if the connection has been made successfully.
11. To save the terminal setup go to *File / Save As* and save settings. When restarting the programme the settings can be loaded directly by double-clicking on the \*.ht icon that has been created. Now actions 4 to 9 can be omitted.

**11 PROGRAMMING VIA THE RS232 INTERFACE** (continued)

Logging data to a file using Microsoft HYPERTERMINAL.EXE

1. Run the HyperTerminal programme with the correct settings.
2. Set up the radiometer and send the command 's' via HyperTerminal to transmit data continuously from the radiometer.
3. Go to *Transfer / Capture Text*. Enter the filename for the stored data and the location to save to. (e.g. C:\HyperTerminal\Capture.txt).
4. Press the *start* button to store all the readings transmitted from the radiometer in a file *Capture.txt*. The status bar will now show a highlighted 'Capture' message. The file is saved to the computer by selecting *Transfer / Capture Text / Stop*.
5. Send the command 's' again via HyperTerminal to stop the continuous transmission of data from the radiometer.

Macam Photometrics Ltd.  
10 Kelvin Square  
Houstoun Industrial Estate  
Livingston  
Scotland EH54 5PF

Telephone: 01506 437-391  
Facsimile: 01506 438-543  
E-mail: [info@macam.com](mailto:info@macam.com)  
Web: [www.macam.com](http://www.macam.com)